

1460  
STANDARD OUTER FRAME PROFILE

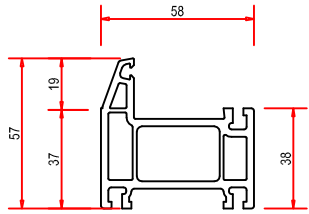

1469  
STANDARD TRANSOM OR MULLION

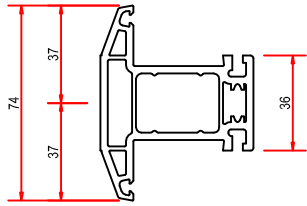

1471  
OPTIONAL RAIL (MID-RAIL)

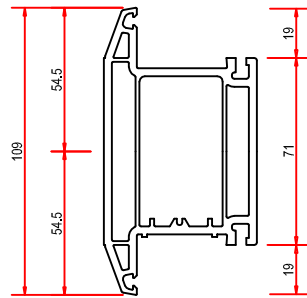

1466-1348 / 1470  
Z CONFIGURATION OPEN IN

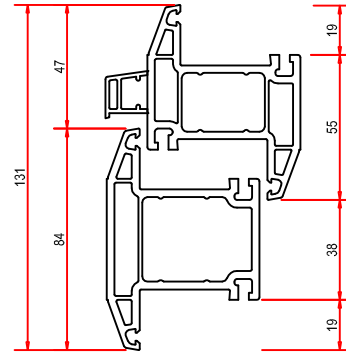

1478 / 1477 / 1479  
OPTIONAL LARGER RAIL

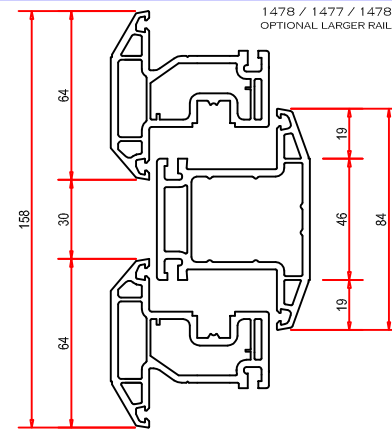

1461  
OPTIONAL LARGER OUTER FRAME PROFILE

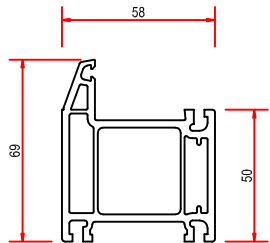

1470  
OPTIONAL LARGER TRANSOM OR MULLION

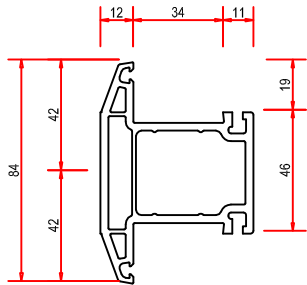

1478 / 1469 / 1478  
TYPICAL MULLION DETAIL AT A VENTED BUTTMENT

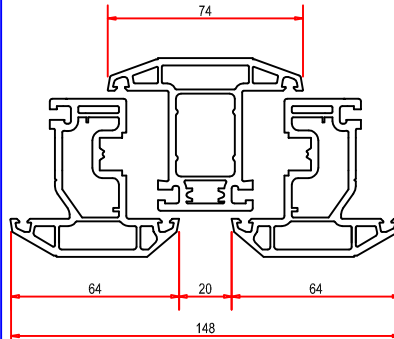

1461 / 1461  
DEFAULT OUTER FRAME & SASH  
SASH ON OPEN IN DOORS

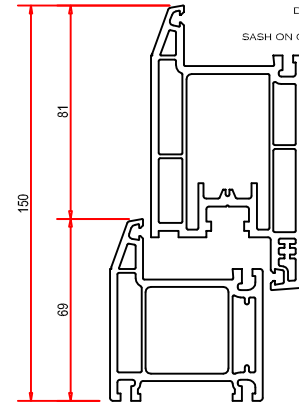

1473 / 1461  
DEFAULT OUTER FRAME & SASH  
SASH ON OPEN OUT DOORS

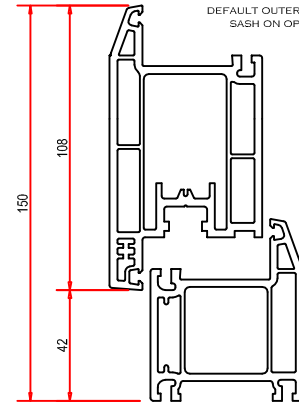

1478 / 1460  
TYPICAL HEAD & JAMB DETAIL FOR VENTED OPTION

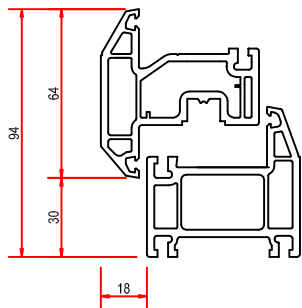

1478 / 1466  
TYPICAL TRANSOM DETAIL WITH DEFAULT SASH  
VENTED SECTION ON A FIXED UNIT

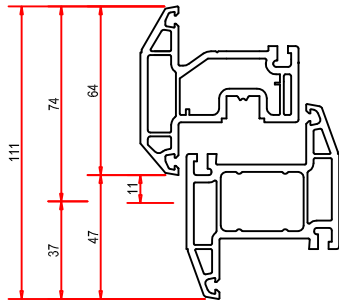

1468 / 1476  
TYPICAL TRANSOM DETAIL WITH LARGER Z SECTION  
VENTED SECTION ON A FIXED UNIT

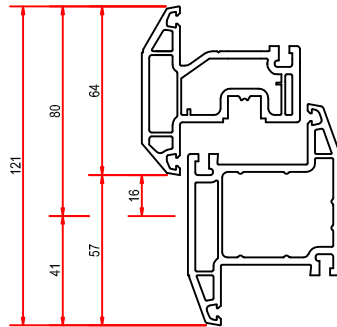

1460 / 0991 CILL  
TYPICAL CILL DETAIL & FIXED WINDOW

